



Turbo MV3 series battery charger

Operation Manual



Manufacturer's P/N	Model	# 12V Output	Total Output
58301	Turbo M212V3	2	12 Amps
58303	Turbo M220V3	2	20 Amps
58304	Turbo M320V3	3	20 Amps
58305	Turbo M230V3	2	30 Amps
58306	Turbo M330V3	3	30 Amps
58307	Turbo M430V3	4	30 Amps
58308	Turbo M240V3	2	40 Amps
58309	Turbo M340V3	3	40 Amps
58310	Turbo M440V3	4	40 Amps

Important Notice

This manual contains important safety, operation, and installation instructions. Please read all the instructions before using your Powermania Turbo MV3 onboard battery charger.



WARNING: CHECK BATTERY TYPE

This charger is designed to charge only certain types 12V DC batteries; Flooded Lead-Acid, AGM (Absorbent Glass Mat), and some LiFEPO4 (Lithium Iron Phosphate). Use this product to charge other types of batteries may cause batteries to burst and result in personal injuries. If you are unsure about the type of battery, please consult with battery manufacturers.



WARNING: RISK OF EXPLOSIVE GASES!

Working in the vicinity of lead-acid batteries is dangerous. Batteries generate explosive gases during normal operation. For this reason, it is extremely important to follow the safety instructions each time you use the charger.



WARNING: DO NOT USE 2-PIN AC ADAPTER/EXTENSION CORD

Do NOT use the charger with a 2-pin AC adapter or extension cord. Do NOT cut or make any modification to the factory equipped AC power cord. Doing so can result in serious personal injury.



CAUTION: CONNECT ONLY TO PROPERLY GROUNDED OUTLET

The charger MUST ONLY be connected to a properly grounded AC outlet that is protected by Ground Fault Circuit Interrupter (GFCI) breaker.



DANGER: ALWAYS UNPLUG AC POWER CORD BEFORE MAKING ANY DC WIRING CONNECTION

The AC power cord MUST be UNPLUGGED from the outlet BEFORE connecting any DC wires to the batteries or making any DC wiring connection change. Failure to do so may cause electrical shock resulting in serious personal injury or death.

Introduction3

Personal safety precautions3

Precautions before charge battery.....3

Box contents.....4

Specifications5

Feature Highlights8

Installing the charger.....10

Installation illustration11

Select battery type12

Connect the DC cables.....13

Operating the charger.....17

LED indicator descriptions17

Troubleshooting.....18

Troubleshooting - Battery Isolation Test.....19

Maintaining the charger19

Fuse replacement instruction20

Warranty and service information21

Contact information21

Optional Accessories21

Warranty card.....22

INTRODUCTION

Thank you and congratulations on your new purchase of the Powermania Turbo MV3 series onboard battery charger. This charger is waterproof, corrosion-resistant and shock-resistant—ideal for recharging and maintaining 12V DC batteries in various marine applications and other harsh environments.

Featuring Automatic 3-Stage Smart Charge and Battery Selector, this charger is designed to charge and maintain various types of 12V DC batteries using full automation. Our charging process has been proven to bring out the batteries' full potential after each charging session while also extending the batteries' lifespan at the same time.

The Turbo MV3 also comes equipped with extensive safety features and intuitive LED indicators to help protect your investment. Please visit our website www.powermaniausa.com for the latest product updates and information.

PERSONAL SAFETY PRECAUTIONS

1. Someone should be within the range of your voice or close enough to come to your aid when working near a Lead-acid or lithium battery.
2. Always work in a well-ventilated area and away from ignition sources.
3. Have plenty of freshwater and soap nearby in case battery acid comes in contact with skin, clothes, or eyes.
4. Wear complete eye protection and protective clothing. Avoid touching your eyes while working near batteries.
5. If battery acid contacts your skin or clothing, wash them immediately with soap and water. If acid enters eyes, immediately flood the eyes with running cold water for at least ten (10) minutes and get medical attention.
6. Never smoke or allow an open flame near batteries.
7. Do not drop any type of metal tool onto battery terminals as that may cause a spark or short-circuit which may result in an explosion or fire.
8. Remove all personal metal items such as rings, bracelets, necklaces, and watches when working near batteries. A battery can cause short circuit currents that are high enough to weld metals and cause serious burns.

PRECAUTIONS PRIOR TO CHARGING BATTERY

- Do not charge outside of the battery manufacturer's recommended temperature conditions.
- Do not use this charger to charge dry cell batteries for home appliances.
- Do not operate the charger if any of the prewired cables or LED's are damaged.
- Make sure all onboard connected electronic devices are powered off.
- If a battery needs to be removed from the vehicle or boat to be charged, always remove the

grounded negative terminal from the battery first.

- Be sure to have enough open space around the battery for good ventilation during charge.
- Wear full eye protection when cleaning battery terminals to prevent corrosive materials from getting in contact with eyes.
- Add distilled water in each cell until battery acid reaches levels specified by the battery manufacturer. Do not overfill. For batteries without cell caps, follow the recharging instructions provided by battery manufacturers.
- If necessary, use only industrial-grade, UL approved extension cord that connects to the charger. When using an extension cord, connect the charger end first before you plug the extension cord to a power outlet. When unplugging, unplug the end connecting to the power outlet first, and then unplug the end connects to the charger.
- Do not bend the AC power cord or extension cord repetitively, especially in the same area.
- Make sure the AC power outlet you are connecting to the charger is GFCI (Ground Fault Circuit Interrupt) protected.

BOX CONTENTS

- Turbo MV3 series battery charger
- Operation manual / Registration card
- Mounting screws

SPECIFICATIONS

	M212V3	M220V3	M320V3	M230V3
Manufacturer's P/N	58301	58303	58304	58305
Max. Input Current (@120V AC)	2.2 Amps	2.7 Amps	2.7 Amps	5.9 Amps
# 12V Output / Total Maximum Amp	2 output / 12 Amp	2 output / 20 Amp	3 output / 20 Amp	2 output / 30 Amp
AC Wire Gauge / DC Wire Gauge	18 AWG (AC) / 14 AWG (DC)	18 AWG (AC) / 12 AWG (DC)	18 AWG (AC) / 12 AWG (DC)	16 AWG (AC) / 12 AWG (DC)
Output Voltage Configuration	2x12V or 1x24V DC	2x12V or 1x24V DC	3x12V or 1x24V + 1x12V or 1x36V DC	2x12V or 1x24V DC
Weight	7.8 lb.	8.0 lb.	8.5 lb.	14.2 lb.
Dimension (Inch)	8 ⁵ / ₈ x 6 ⁷ / ₈ x 3	8 ⁵ / ₈ x 6 ⁷ / ₈ x 3	8 ⁵ / ₈ x 6 ⁷ / ₈ x 3	10 ³ / ₄ x 8 ³ / ₈ x 3 ⁵ / ₈
Cooling Fan	No	Yes	Yes	Yes

M330V3	M430V3	M240V3	M340V3	M440V3
58306	58307	58308	58309	58310
5.9 Amps	5.9 Amps	7.2 Amps	7.2 Amps	7.2 Amps
3 output / 30 Amp	4 output / 30 Amp	2 output / 40 Amp	3 output / 40 Amp	4 output / 40 Amp
16 AWG (AC) / 12 AWG (DC)	16 AWG (AC) / 12 AWG (DC)	16 AWG (AC) / 12 AWG (DC)	16 AWG (AC) / 12 AWG (DC)	16 AWG (AC) / 12 AWG (DC)
3x12V or 1x24V + 1x12V or 1x36V DC	4x12V or 1x36V + 1x12V or 1x48V*	2x12V or 1x24V DC	3x12V or 1x24V + 1x12V or 1x36V DC	4x12V or 1x36V + 1x12V or 1x48V*
14.8 lb.	15.3 lb.	14.6 lb.	15.2 lb.	16.0 lb.
10 ^{3/4} x 8 ^{3/8} x 3 ^{5/8}	10 ^{3/4} x 8 ^{3/8} x 3 ^{5/8}	10 ^{3/4} x 8 ^{3/8} x 3 ^{5/8}	10 ^{3/4} x 8 ^{3/8} x 3 ^{5/8}	10 ^{3/4} x 8 ^{3/8} x 3 ^{5/8}
Yes	Yes	Yes	Yes	Yes

* Each 12V output bank needs to be connected to a 12V battery. Batteries can be independent, linked in parallel, or linked in series.

Specification (All models)

SPECIFICATIONS (All models)

Input voltage:	120/240V AC
Input frequency:	50/60Hz
Output voltage:	13.4V ~ 14.8V DC
Battery type setting:	1. Flooded (Lead-Acid) / AGM 2. 14.6 CV (Constant Voltage) 3. AGM+
Max. Absorption time:	3 hours
Output cable length:	6 feet / 182 cm
Power cord length:	6 feet / 182 cm
LED indicators (top):	1. Power 2. Monitor On 3. Float Charge On 4. Error 5. AGM+ charge mode 6. 14.6 CV charge mode 7. Flooded (Lead-Acid) / AGM charge mode
LED indicators (bottom):	Charge status / DC connection check
Feature highlights:	Adaptive Loading 3-Stage Smart Charge Battery Type Selector
Safety features:	Ignition Protection Overheat Protection Over-Current Protection Over-Voltage Protection Reverse Polarity Protection Short Circuit Protection
Design standard & Compliances:	FCC Part 15 Class A IP65 (Splash-proof) Marine UL 1236 CSA C22.2 No. 107.2 California Energy Commission (CEC)

FEATURE HIGHLIGHT: Adaptive Loading



USER BENEFIT:	Fully charges all connected batteries in the shortest time.
----------------------	---



The Adaptive Loading feature adjusts the charger’s output level automatically and dynamically on each output bank. This function allows more charging power goes to the more depleted battery, and less power goes to the battery that is closer to full charge.

In Scenario 1 (left chart), the two batteries have a similar state of charge. The Turbo MV3 charger allocates approximately even 50% of its total output to each battery. In Scenario 2 (right chart), the first battery is close to full charge, but the second battery is deeply depleted. In this case, Adaptive Loading allocates 10% of its charging amperage to the first battery and the rest 90%* to the discharged one.

In both scenarios, the charger uses its full output - maximum amperage, unlike chargers with fixed output-per-bank, the Turbo MV3 charges all connected batteries in the shortest time possible.

* Due to safety precautions, the maximum current is limited to 25 Amp per output.

FEATURE HIGHLIGHT: 3-Stage Smart Charge



USER BENEFIT:	Maximizes battery potential and prolongs battery life.
----------------------	---

Turbo MV3 charges a battery in three sequential stages: Bulk, Absorption, and Monitor / Float. This method is proven to bring a battery to its fullest charge, as well as maintain a fully charged battery's from self-discharge.

At the first stage (Bulk), the charger provides its maximum constant current for fast charging. The battery's voltage increases as it absorbs the charge. When the battery voltage reaches 14.5V (Lead Acid /AGM mode), it's approximately 85% recharged. The charger then moves to the second stage.

At the second stage (Absorption), the charger continues to charge the battery at 14.5V (Lead Acid / AGM mode). The charging current drops as the battery charged up to 100%. When the batteries reach full charge, the charger then moves to the third stage.

At the third stage (Monitor / Float), the charger first goes to idle (no Float charge) while monitors the batteries' state of charge. If the voltage of battery #1 (battery connected by output #1) falls below 12.5V, the charger restarts a new charge cycle. After a set idle period, the charger begins to apply float voltage at 13.4V (Lead Acid / AGM mode) and continues to monitor. It is safe to keep the charger connected to the battery indefinitely to maintain the battery's full charge.

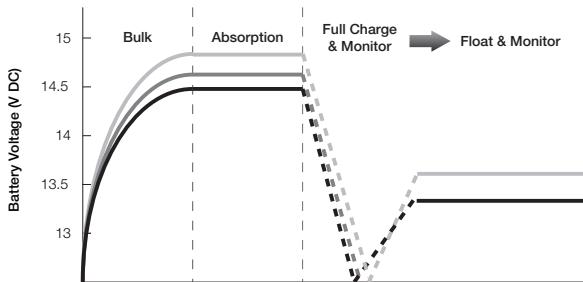

Line	LED	Charge Mode	Voltage (Absorption)	Voltage (Float)
	L. Acid AGM	Lead-Acid /AGM	14.5 V DC	13.4 V DC
	14.6 CV	14.6 Const. Voltage*	14.6 V DC	0 V DC
	AGM+	AGM+**	14.8 V DC	13.6 V DC

* 14.6 CV Mode is designed for recharging LiFePO4 (Lithium Iron Phosphate) batteries. Please consult battery manufacturer for compatibility.

** AGM+ Mode is designed for recharging TTPL (Thin Plate Pure Lead) AGM batteries. This charging profile has been approved by Odyssey and NorthStar battery company.

INSTALLING THE CHARGER

The Powermania Turbo MV3 series charger is designed to be mounted onboard a vehicle or watercraft. Please refer to the illustration on the next page for the optimal mounting orientation. The top row LED lights should line up horizontally at the top and the output cables at the bottom of the charger. This orientation optimizes air ventilation during operation. Follow these instructions for a proper charger installation:

1. Select a well-ventilated area where there are at least 8 inches of clearance around the charger. Make sure the mounting surface can firmly support the charger with the provided screws. **Do NOT install the charger near any combustible or flammable materials such as a fuel tank or a compartment filled with gasoline vapors.**
2. Make sure the charger's DC output cables can reach all batteries from the mounting location. **Do NOT lay cable or any wire in direct contact or adjacent to the charger's case as the charger could reach a high temperature and possibly cause a fire hazard to the cable.**
3. If the DC cables are not long enough, they may be extended by adding Powermania tool-free DC extension kit (available in 5', 10', or 15' length) - Accessory P/N 10521 (5'), 10522 (10'), and 10523 (15'). If it is necessary to cut and splice the wires, use only UL certified marine grade 12 AWG for 15 Amp and 20 Amp models, and 10 AWG for 30 Amp and 40 Amp wires. Each splice should be covered by adhesive lined / dual wall heat shrink tube to prevent corrosion at the joints. The splicing should be made between the fork of the cable and the fuse holder so that the fuse stays within 6" of the battery terminals. Do not add more than 15' of DC cable extension. Do NOT lay cable or any wire in **Making any modification to the factory-equipped cables will void the warranty.**
4. Support the charger and position it on the tentative mounting area. Use a pencil to mark the position of each mounting hole.
5. Use 1/8" drill bit to drill on the marked position.
6. Align the charger to the drilled holes, and then secure the charger with the provided screws.

INSTALLATION ILLUSTRATION

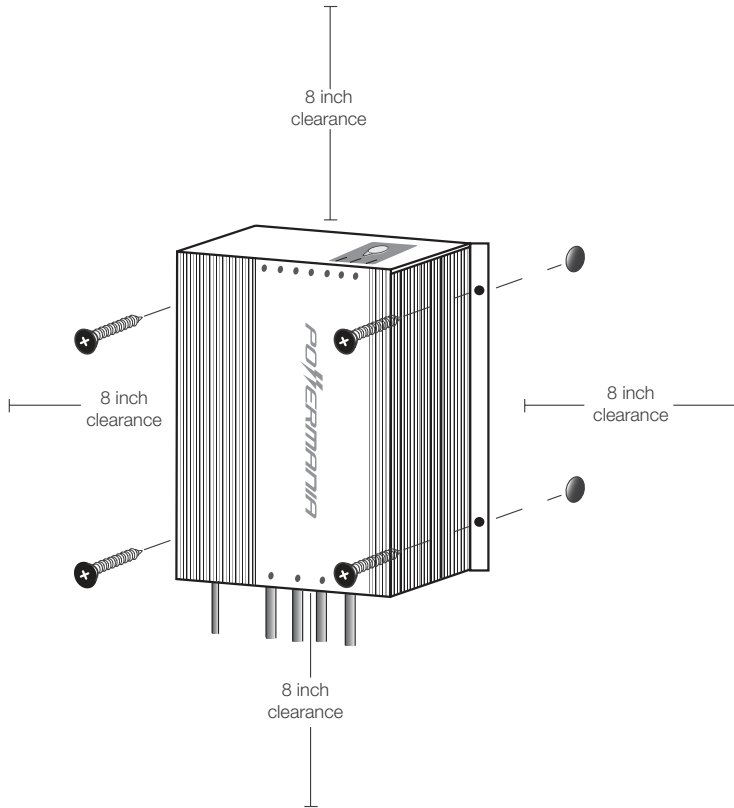

DIMENSIONS AND MOUNTING MEASUREMENT

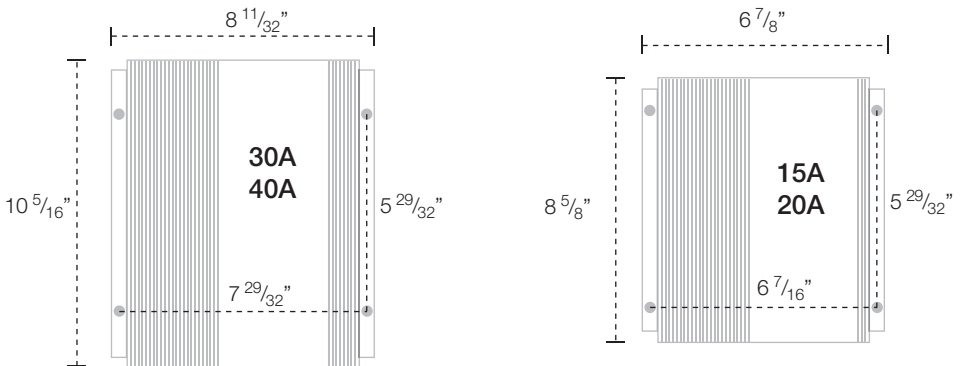

SELECT BATTERY TYPE

The Battery Selector has three settings. From left to right, the first position (factory setting) is for charging most of Flooded Lead-Acid and AGM batteries. Set the selector to the middle position (14.6CV) for charging Lithium Iron Phosphate (LiFePO₄) batteries*. The right position (AGM+) is for charging Thin Plate Pure Lead (TPPL) AGM battery (Odyssey and Northstar AGM's). If there is more than one battery type, choose a profile with charging and maintaining voltages fall in ranges of all the connected batteries. Refer to page 9 for voltages in different settings.

* Please consult Lithium battery manufacturer for charging compatibility. When setting up a charging system for LiFePO₄ batteries, it is recommended using a dedicated Turbo MV3 charger for a single application. For example, use a three-bank charger dedicated for a 36V (three 12V in series) Lithium battery set up. Do NOT use the same charger for multiple lithium battery applications such as mixing trolling motor batteries and starting batteries - even if they are all LiFePO₄ batteries.

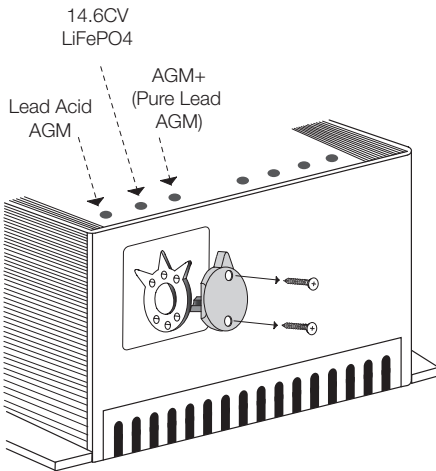

To change Charging Profile Setting:

1. Make sure the charger's power cord is unplugged from the power outlet.
2. Loosen the screws from the battery type selector.
3. Carefully pull the battery selector straight out from the charger.
4. Place the battery selector back to the charger with the desired battery type position.
5. Secure the screws back to the battery selector.



CAUTION: RISK OF PERSONAL INJURY

Do NOT use any other screws that are not provided by Powermania to tighten the selector cap. Using unauthorized screws could damage the charger and result in serious personal injury.



EVERY DC OUTPUT MUST BE CONNECTED TO A 12V BATTERY FOR PROPER OPERATION.

CONNECT THE DC CABLES

The following pages demonstrate proper DC wiring configurations for Powermania Turbo MV3 series chargers. When making DC connections, make sure connecting the same set of positive and negative connectors to the same 12V battery. The red wires are positive (shown as grey color on the diagrams), and the black ones are negative. It is critical not to mix up polarity when making a connection.

ALL of the charger's output cables must be connected to batteries. Never leave any output unconnected. If there is a spare output left unused, double up the spare output to a 12V battery that's already been connected by another one.

Connect the charger's first output (output #1) to the main house battery, or the battery that's typically got most depleted. Output #1 is located next to the AC cord.

Please refer to the following legend used in the connection diagrams.



Fuse holder



Positive output (Red wire)



Negative output (Black wire)



Jumper cable (not included)



AC input power cord

Connecting a dual output charger to a single 12V battery

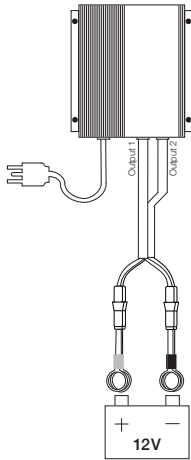

Connect both sets of DC outputs to the same battery's terminal. **DO NOT LEAVE ANY SPARE OUTPUT UNCONNECTED.**

Connecting a 12V output to two 6V batteries

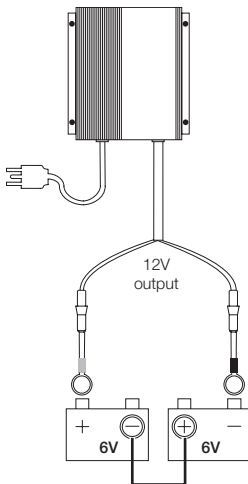

If a 12V system is composed of two 6V batteries, connect the output's positive terminal ring to battery #1's positive terminal and the same output's negative ring terminal to battery #2's positive terminal.

Connecting a dual output charger to two serial-connected 12V batteries (24V system)

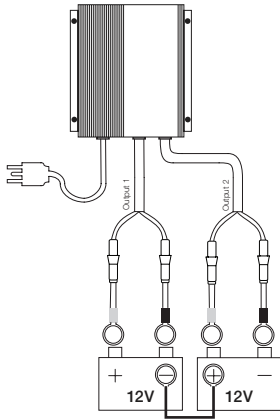

Connect each set of output to each 12V battery. The jumper can be left connected between the two batteries during charging.

Connecting a dual output charger to two parallel-connected 12V batteries

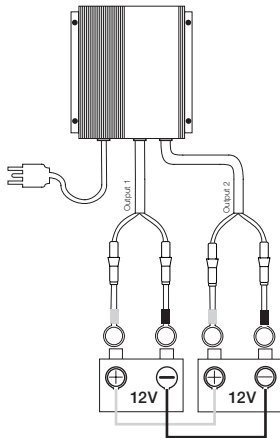

Connect one set of output to each 12V battery. The jumper can be left connected between the two batteries during charging.

Connecting a triple output charger to three 12V batteries

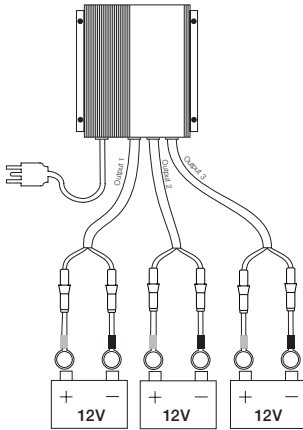

The batteries could be independent, serial-connected or parallel-connected. If connecting a quad output charger to three 12V batteries, connect the spare output to any one of the three (preferably the weakest) batteries.

Connecting a quad output charger to four 12V batteries

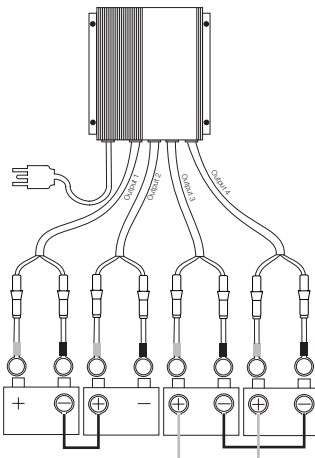









The batteries could be independent, serial-connected, parallel-connected, or mix-and-matched.

OPERATING THE CHARGER

1. Install the charger and make appropriate DC wiring connections according to the diagrams.
2. Choose an appropriate setting on the Battery Selector (page 12).
3. Plug in AC power cord to a properly grounded outlet. Avoid repeatedly bending a section of the power cord. Make sure the power cord and the extension cable are not frayed.
4. The Power indicator LED will display green, indicating the presence of AC power.
5. The charger will go through a short test cycle checking if all the DC outputs are correctly connected to 12V batteries.
6. For models equipped with a cooling fan, the fan could be turned on and off automatically based on the ambient and charger's temperature.
7. The charger will start a new charge cycle. The charge status lights will display red.
8. After all the batteries reach full charge, the charger will go into Monitor mode (Monitor On), in which the charger becomes idle. If the charger is left plugged in continuously for 30 hours, it will then apply float voltage (Float On). It is safe to leave the charger plugged in indefinitely. At any time during Monitor On, if battery #1 loses a significant amount of charge, the charger will automatically start a new recharge cycle.

LED INDICATOR DESCRIPTION

Icon	Indicator	Description
	Power	Power on
	Monitor On	Monitor mode on
	Float On	Float Charge on (No Float charge if 14.6 CV Mode is selected)
	Error	Error. Proceed to Troubleshooting
	AGM+ Charge Mode	AGM+ Charge Mode (for Odyssey & Northstar TPPL AGM batteries)
	14.6 CV Charge Mode	14.6 CV Charging Mode (for Lithium Iron Phosphate - LiFePO4)
	Flood lead-acid & AGM Charge Mode	Flood lead-acid & AGM Charge Mode (for most brand's lead-acid / AGM batteries)
	Charge Status / Connection Check	Red: Charging Green: Ready Amber: DC connection fault



DANGER:

ALWAYS DISCONNECT AC POWER CORD PRIOR TO MAKING ANY DC WIRING CONNECTION CHANGE OR WHEN CHECKING FUSES.

TROUBLESHOOTING

Problem	Possible Cause	Solution
No LED On	No AC input	Check AC input connection. Try with a different AC outlet to make sure AC power is present.
Error LED On	Charger detects battery voltage exceeds the range for one or more outputs	Check and correct battery wiring connection. (Refer to DC wiring diagrams) Make sure each output is connected to <u>one 12V battery</u> . Wait at least 30 seconds before plugging in AC power again. If Error LED continues to be on after wiring correction, conduct Battery Isolation Test (page 19).
	Charger or ambient temperature exceeds the range	Remove objects obstructing airflow around the charger. If the charger was exposed under direct sunlight, move it away from direct sunlight exposure. Once the temperature drops below the threshold, the charger will automatically start again.
Charge Status / Connection Check LED displays amber	One of more outputs is not connected to a 12V battery	Properly connect the DC output to a 12V battery. Refer to DC wiring diagrams.
	Fuse failure	Check for blown fuses in the output cables. Replace damaged fuses. Refer to page 19 for fuse replacement instruction.
	Faulty terminal connections	Clean battery terminal and tighten all wiring connections.
	Reverse polarity on DC wiring connections	Make sure connections have a matching polarity. Check fuses on output cables and replace any damaged fuse.
	Defective battery	Perform battery test. Replace defective batteries.
Charge Status stuck in Red (Charging) for too long	Devices drawing power from battery	Turn off or disconnect all devices connected to the batteries. Conduct Battery Isolation Test (page 19).

BATTERY ISOLATION TEST

The Battery Isolation Test could help identify whether an error is caused by the charger or by one of its connected batteries, which could be defective.

1. Check all inline fuses on all outputs.
2. Combine all of the charger's outputs to just one 12V battery - choose a battery that is NOT previously connected by output #1.
3. Plug in the AC power cord and observe if the charger runs a normal charging cycle and brought the connected battery to full charge.
4. Repeat the same test to another 12V battery.
5. If the charger completes a full, normal charging cycle in only one of the two tests, it may be a battery's defect. Bring that battery to a battery shop for a further load test.
6. If the charger performs full, completed charging cycles in both tests, it may be a connection error from the previous set up.
7. If the charger returns error LED in both tests, contact Powermania to check for warranty coverage.

MAINTAINING THE CHARGER

The Powermania Turbo MV3 charger requires no specific maintenance. However, it is recommended to do the following to ensure reliable and optimal performance from your battery:

- Regularly clean battery terminals and charger's output ring terminals with baking soda and tighten all DC wiring connections.
- Regularly check and maintain proper battery electrolyte level following battery manufacturer's instructions.

It is recommended that you keep the charger plugged in to maintain a proper charge level of the connected batteries during long storage periods. This method has been proven to extend battery life and optimal performance.

FUSE REPLACEMENT INSTRUCTION

- Make sure the charger's AC power cord is unplugged. Disconnect all the DC outputs from batteries.
- For models using cylinder (AGC-1) style fuse, pull the fuse holder straight apart. Do not bend the fuse holder as it will break the fuse inside. If necessary, use a hairdryer to warm up the fuse holder and adding grip could ease pulling it apart.
- For the matchbox (ATU) style fuse holder used in M240V3, open the cap.
- Remove any blown fuse by pulling it straight up and out. Do not apply excessive squeezing force as it can break the fuse. If the fuse is broken inside the fuse holder, use long nose pliers to remove the broken pieces carefully.
- For AGC-1 fuse holders, use pliers to gently press the outside of rubber enclosure as illustrated in the diagram below. Do not apply excessive force as it could deform the inner metal plate and create an uneven contact area. When inserting the fuse, it should sit snugly inside the fuse holder. The round metal ends of the fuse should have a full and even contact with the round metal plates.
- For the ATU fuse holder, use long nose pliers to gently push in the U-shaped section of the metal plate to form a horseshoe shape. This adjustment will maximize the conducting area between the fuse and the holder and provides a proper connection for electricity and heat transfer.

AGC-1

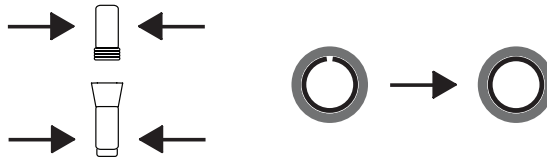

ATU



- Always replace a new fuse of the same rating. The following table list the fuse ratings used for each Turbo MV3 model.

Style	Model	Fuse Rating
AGC-1	M212V3	15 Amp
AGC-1	M220V3 / M320V3	25 Amp
AGC-1	M230V3 / M330V3 / M430V3 / M340V3 / M440V3	30 Amp
ATU	M240V3	40 Amp

- Make sure the new fuse is pushed into the holder securely.
- Close the cap / holder until it's tight.

WARRANTY AND SERVICE INFORMATION

Powermania, at its discretion, provides a 2-year limited warranty on Turbo MV3 chargers against defects in material or workmanship under normal use. The warranty coverage period is calculated as follows:

- If the customer provides a valid purchase receipt, the two-years coverage begins from the date of purchase.
- If the customer cannot provide a valid purchase receipt, the two-years coverage begins from the manufacture date. The manufacture date is embedded in the unit's serial number.

The following conditions are NOT covered under warranty:

- Physical damage
- Normal wear and tear
- Damage caused by accidents, misuse, or alteration of the product, including cutting or splicing AC/DC cables.

You may contact Powermania directly for service or warranty inquiry. Please note that customers are responsible for paying the cost of shipping the defective product to Powermania.

CONTACT INFORMATION

Powermania, Inc.

39 E Airway Blvd

Livermore, CA 94551

Tel: 408.228.4868

Fax: 408.228.4878

email: support@powermaniausa.com

www.powermaniausa.com

OPTIONAL ACCESSORIES

P/N	10501	Through Hull AC Plug Port (Black)
P/N	10502	Through Hull AC Plug Port (White)
P/N	10521	DC Extension Kit (5')
P/N	10522	DC Extension Kit (10')
P/N	10523	DC Extension Kit (15')



Product Registration Card

Register online at www.powermaniausa.com

Model number:

Serial number:

58xxx number found on the sticker on
the surface plate of the charger.

First & Last name:

Address:

City:

State:

Zip:

Email:

Telephone:

Date of Purchase (mm/dd/yyyy):

Purchased from (Dealer):

Type of application:

Comments:

www.powermaniausa.com

Place
Stamp
Here

Save a stamp and register online at
PowermaniaUSA.com/registration.php

Powermania, Inc.
39 E Airway Blvd
Livermore, CA 94551
USA

POWERMANIA[®]

Don't just Charge. *Turbo* Charge.